

The data to be read in conjunction with the Hydrogen Thyatron Preamble.

ABRIDGED DATA

Deuterium-filled tetrode thyatron with ceramic/metal envelope, featuring low jitter, firing time and drift. Suitable for switching high power at high pulse repetition rates or for switching long pulses. A reservoir operating from a separate heater supply is incorporated.

Peak forward anode voltage 40 kV max
 Peak anode current 3.0 kA max
 Average anode current 2.0 A max

GENERAL DATA

Electrical

Cathode (connected internally to one end of heater) oxide coated
 Cathode heater voltage $6.3 \begin{smallmatrix} + 0.5 \\ - 0.0 \end{smallmatrix}$ V
 Cathode heater current 22.5 A
 Reservoir heater voltage (see note 1) 5.0 V
 Reservoir heater current 7.0 A
 Tube heating time (minimum) 15 min
 Anode to grid 2 capacitance 15 to 20 pF

Mechanical

Seated height 165.1 mm (6.500 inches) max
 Clearance required below mounting flange 38.1 mm (1.500 inches) min
 Overall diameter (mounting flange) 111.1 mm (4.375 inches) nom
 Net weight 1.8 kg (4 pounds) approx
 Mounting position (see note 2) any
 Tube connections see outline

Cooling liquid or forced-air
 Liquid oil or coolant immersion
 Forced-air see below

Cooling by oil or coolant immersion is preferred in view of the high voltages present. Further information is contained in the relevant section of the Preamble.

The tube may be cooled by forced-air directed mainly onto the base, and the metal/ceramic envelope should be maintained below the maximum rated temperature. An air flow of at least 2.83 m³/min (100 ft³/min), depending on the mechanical layout, will be necessary to keep the tube operating temperatures under the limits specified below.

In addition to 200 W of heater power, the tube dissipates from 100 W per ampere average anode current, rising to 300 W/A at the highest rates of rise and fall of anode current.



The cathode end of the tube must be cooled whenever heater voltages are applied, since the cathode flange will reach a temperature of 120 °C above ambient in the absence of cooling.

Envelope temperature:

ceramic, anode and grids 150 °C max
 cathode flange and base 120 °C max

MAXIMUM AND MINIMUM RATINGS (Absolute values)

These ratings cannot necessarily be used simultaneously, and no individual rating must be exceeded.

	Min	Typical	Max	
Anode (Pulse Modulator Service)				
Peak forward anode voltage (see note 3)	-	-	40	kV
Peak inverse anode voltage (see note 4)	-	-	35	kV
Peak anode current	-	3.0	-	kA
Peak anode current (pulse repetition rate limited to 60 pps max)	-	-	4.0	kA
Average anode current	-	-	2.0	A
Rate of rise of anode current (see notes 5 and 6)	-	-	-	kA/μs
Pulse repetition rate	-	400	-	pps

	Min	Max	
Anode (Single-Shot)			
DC forward anode voltage	-	30	kV
Peak anode current	-	10	kA
Rate of rise of anode current	-	-	see note 5
Total conducted charge:			
capacitor discharge	-	0.1	C
power supply follow-on (see note 7)	-	4	C
Repetition frequency	-	-	1 pulse per 10 s max

Grid 2

Unloaded grid 2 drive pulse voltage (see note 8)	500	2000	V
Grid 2 pulse duration	0.5	-	μs
Rate of rise of grid 2 pulse (see note 6)	10	-	kV/μs
Grid 2 pulse delay	0.5	3.0	μs
Peak inverse grid 2 voltage	-	450	V
Loaded grid 2 bias voltage	-50	-200	V
Forward impedance of grid 2 drive circuit (see note 9)	50	500	Ω

Grid 1 - Pulsed

Peak grid 1 drive current	0.3	1.0	A
Unloaded grid 1 drive pulse voltage (see note 8)	300	1000	V
Grid 1 pulse duration	2.0	-	μs
Rate of rise of grid 1 pulse (see note 6)	1.0	-	kV/μs
Peak inverse grid 1 voltage	-	450	V
Loaded grid 1 bias voltage	-	-	see note 10

Grid 1 - DC Primed (See note 9)

DC grid 1 unloaded priming voltage	75	150	V
DC grid 1 priming current	75	150	mA

Cathode

Heater voltage	6.3	6.8	V
Heating time	15	-	min

Reservoir

Heater voltage (see note 1)	4.5	6.5	V
Heating time	15	-	min

Environmental

Ambient temperature	-50	+90	°C
Altitude	-	3	km
	-	10 000	ft

CHARACTERISTICS

	Min	Typical	Max	
Critical DC anode voltage for				
conduction (see note 11)	-	0.5	1.0	kV
Anode delay time				
(see notes 11 and 12)	-	0.1	0.25	μs
Anode delay time drift				
(see notes 11 and 13)	-	15	50	ns
Time jitter (see note 11)				
	-	1.0	5.0	ns
Cathode heater current				
(at 6.3 V)	20	22.5	25	A
Reservoir heater current				
(at 5.0 V)	6.0	7.0	8.0	A

NOTES

- The reservoir heater must be decoupled with a suitable capacitor to avoid damage by spike voltages. The recommended reservoir heater voltage for each individual tube is stamped on the tube envelope. This recommended value is determined for hold-off at the maximum anode voltage under DC conditions. For lower voltages and modulator operation the reservoir heater voltage should be increased to a value consistent with voltage hold-off at the operating level. Maximum reservoir voltage (i.e. maximum gas pressure in the tube) is one prerequisite for maximum thyratron life. The reservoir voltage should be stabilised to ± 0.05 V.
- The tube must be fitted using its mounting flange.
- Under resonant charging conditions a maximum anode voltage of 35 kV is recommended. Using command charging conditions where the voltage appears at the anode for only a short time (<1 ms), this thyratron may be operated up to 40 kV.
- The peak inverse voltage including spike must not exceed 10 kV for the first 125 μs after the anode pulse.
- In single shot or burst mode, this parameter can exceed 150 kA/μs. The ultimate value which can be attained depends to a large extent upon the external circuit.
- This rate of rise refers to that part of the leading edge of the pulse between 25% and 75% of the pulse amplitude.
- Under fault conditions, most of the coulombs are often in the power supply follow-on current, rather than the storage capacitor discharge.
- Measured with respect to cathode. Pre-pulsing of grid 1 is recommended for modulator and high rate of rise of current applications. The last 0.25 μs of the top of the grid 1 pulse must overlap the corresponding first 0.25 μs of the top of the delayed grid 2 pulse.

9. When DC priming is used on grid 1, a negative bias of 100 to 200 V must be applied to grid 2 to ensure anode voltage hold-off. Also the higher grid 1 is pulsed, the larger must the grid 2 negative bias be, to prevent the tube firing on the grid 1 pulse.
10. DC negative bias voltages must not be applied to grid 1. When grid 1 is pulse driven, the potential of grid 1 may vary between -10 and $+5$ V with respect to cathode potential during the period between the completion of recovery and the commencement of the succeeding grid pulse.
11. Typical figures are obtained on test using conditions of minimum grid drive. Improved performance can be expected by increasing grid drive.
12. The time interval between the instant at which the rising unloaded grid 2 pulse reaches 25% of its pulse amplitude and the instant when anode conduction takes place.
13. The drift in delay time over a period from 10 seconds to 10 minutes after reaching full voltage.

HEALTH AND SAFETY HAZARDS

E2V Technologies hydrogen thyratrons are safe to handle and operate, provided that the relevant precautions stated herein are observed. E2V Technologies does not accept responsibility for damage or injury resulting from the use of electronic devices it produces. Equipment manufacturers and users must ensure that adequate precautions are taken. Appropriate warning labels and notices must be provided on equipments incorporating E2V Technologies devices and in operating manuals.



High Voltage

Equipment must be designed so that personnel cannot come into contact with high voltage circuits. All high voltage circuits and terminals must be enclosed and fail-safe interlock switches must be fitted to disconnect the primary power supply and discharge all high voltage capacitors and other stored charges before allowing access. Interlock switches must not be bypassed to allow operation with access doors open.



X-Ray Radiation

All high voltage devices produce X-rays during operation and may require shielding. The X-ray radiation from hydrogen thyratrons is usually reduced to a safe level by enclosing the equipment or shielding the thyatron with at least $\frac{1}{16}$ -inch (1.6 mm) thick steel panels.

Users and equipment manufacturers must check the radiation level under their maximum operating conditions.

SCHEMATIC DIAGRAM

7032

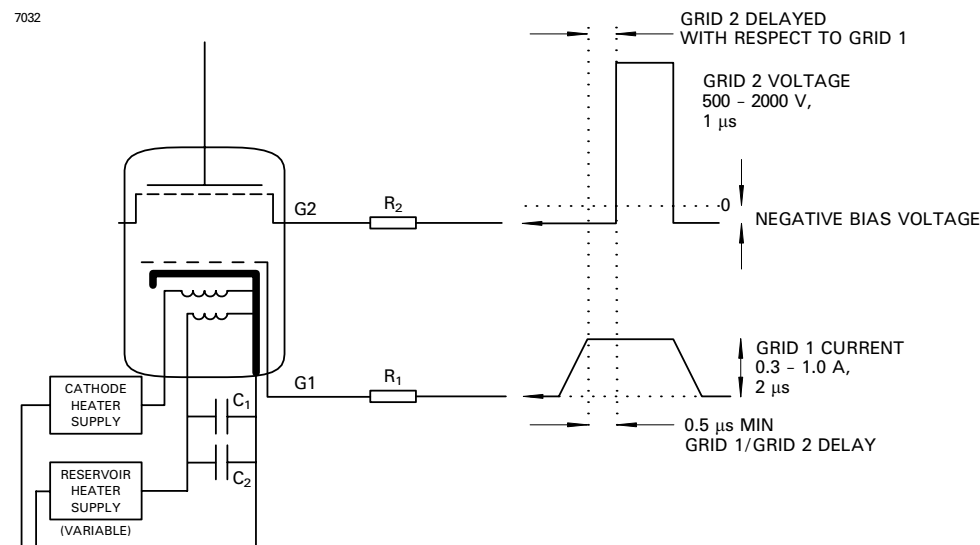

RECOMMENDED GRID, CATHODE AND RESERVOIR HEATER CONNECTIONS

- R_1 = Grid 1 series resistor. 12 W vitreous enamelled wirewound is recommended, of a total impedance to match the grid 1 drive pulse circuit.
- R_2 = Grid 2 series resistor. 12 W vitreous enamelled wirewound is recommended, of an impedance to match the grid 2 drive pulse circuit.
- C_1, C_2 — reservoir protection capacitors with a voltage rating ≥ 500 V;
- C_1 = 1000 pF low inductance (e.g. ceramic),
- C_2 = 1 μ F (e.g. polycarbonate or polypropylene).

Components R_1 , R_2 , C_1 and C_2 should be mounted as close to the tube as possible.

OUTLINE

(All dimensions without limits are nominal)

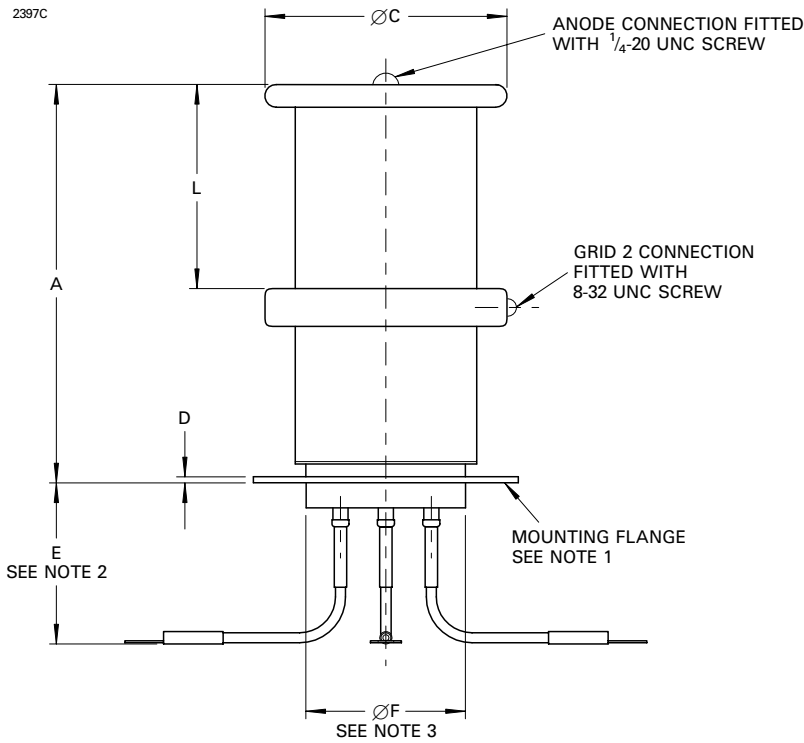

Ref	Millimetres	Inches
A	165.1 max	6.500 max
B	111.13	4.375
C	101.6	4.000
D	2.54	0.100
E	50.8 min	2.000 min
F	69.85 max	2.750 max
G	190.5 min	7.500 min
H	6.35	0.250
J	6.50	0.256
K	95.25	3.750
L	85.73	3.375

Inch dimensions have been derived from millimetres.

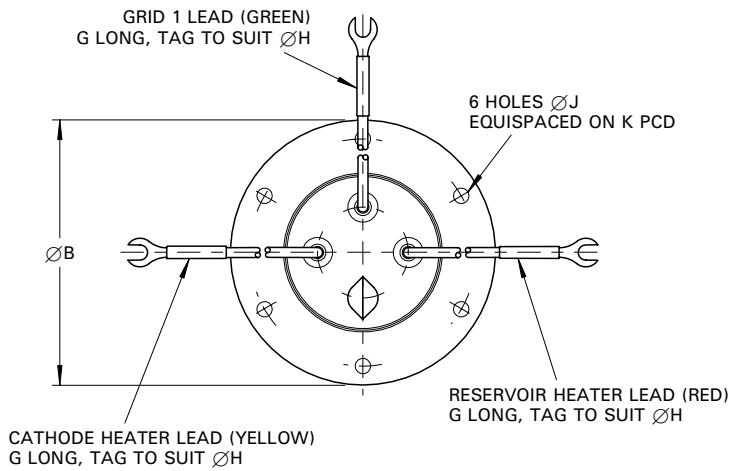

Outline Notes

1. The mounting flange is the connection for the cathode, cathode heater return and reservoir heater return.
2. A minimum clearance of 38.1 mm (1.500 inches) must be allowed below the mounting flange.
3. The recommended mounting hole is 73.0 mm (2.875 inches) diameter.

Whilst E2V Technologies has taken care to ensure the accuracy of the information contained herein it accepts no responsibility for the consequences of any use thereof and also reserves the right to change the specification of goods without notice. E2V Technologies accepts no liability beyond that set out in its standard conditions of sale in respect of infringement of third party patents arising from the use of tubes or other devices in accordance with information contained herein.